

# Electrical and Optical Clock Data Recovery Solutions

- N1076A electrical clock recovery up to 32 GBd
- N1077A optical/electrical clock recovery up to 32 GBd
- N1076B electrical clock recovery up to 64 GBd
- N1078A optical/electrical clock recovery up to 64 GBd



- Electrical and optical clock recovery solutions to 64 GBd:
- Supports NRZ and PAM4 signals
  - Integrated O/E and clock recovery design
  - Optical splitter: Integrated or External - user supplied
  - Ultra-low residual random jitter < 100 fs RMS
  - Jitter spectrum analysis (JSA) capability
  - Golden phase-locked loop (PLL) for compliant operation

## Table of Contents

Electrical and Optical Clock Recovery Solutions.....	3
What Does Clock Recovery Do?.....	4
Why Use Clock Recovery?.....	4
Electrical Clock Recovery .....	5
Optical/Electrical Clock Recovery .....	6
Characterize Next-generation Receivers and Transmitters .....	8
Application Example .....	11
N1076A Specifications.....	12
N1076B Specifications.....	13
N1077A Specifications .....	15
N1078A Specifications.....	17
Ordering Information .....	21
Accessories .....	23

# Electrical and Optical Clock Recovery Solutions

Keysight clock recovery solutions offer a wide data rate range and are ideal for many transmitter and receiver test setups for computers, datacom, and communication standards.

The Keysight Technologies, Inc. electrical clock recovery solutions provide clock recovery capabilities for electrical non-return-to-zero (NRZ) and pulse amplitude modulation 4-level (PAM4) signals.

The Keysight Technologies, Inc. optical/electrical clock recovery integrates electrical clock recovery with an amplified optical-to-electrical (O/E) converter, enabling it to work for both electrical and optical applications. Optional integrated optical splitters are available, which simplifies setup and improves ease-of-use.

All models include adjustable loop bandwidth and selectable peaking, and provide high sensitivity and low intrinsic jitter performance that ensures optimal measurement accuracy. The optional jitter spectrum analysis (JSA) capability provides insight into the magnitude and distribution of low-frequency jitter, which is helpful in troubleshooting root cause for excessive jitter.

Recover clocks from closed eyes: The N1076B electrical clock recovery includes integrated variable equalizers on both electrical inputs to enable opening closed eyes.



## PLL and Jitter Spectrum Analysis

Use Keysight Technologies, Inc. 86100DU-400 PLL analysis software to make fast, accurate, and repeatable measurements of phase-locked loop (PLL) bandwidth/jitter transfer. The N107x can be configured as a jitter receiver, which can be combined with a precision jitter source, such as the Keysight Technologies M8000 Series of BER test solutions, to create a PLL stimulus-response test system. PCI Express®-approved PLL bandwidth compliance tests are pre-configured, with automatic report generation.

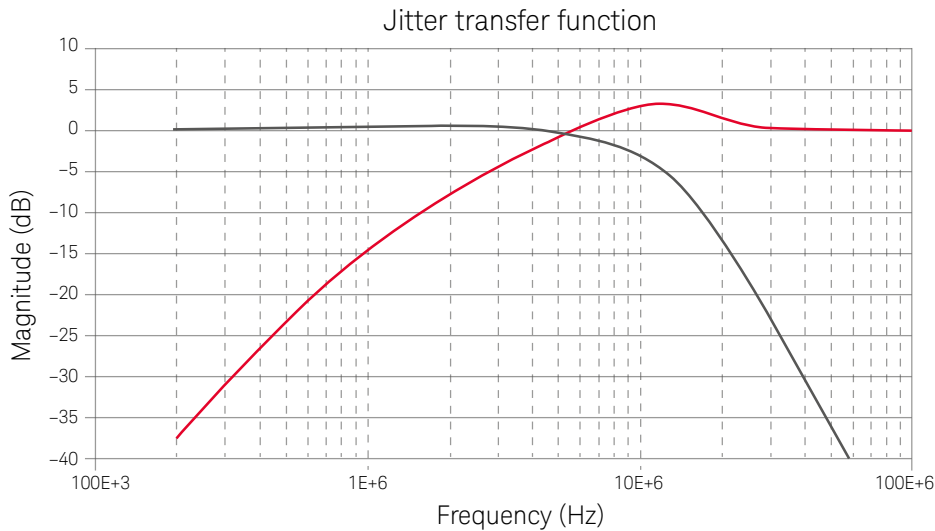

Figure 1. The N107x clock recovery may be configured as a jitter receiver when characterizing phase-locked loop (PLL) designs using 86100DU-400 PLL analysis software.

## What Does Clock Recovery Do?

Clock recovery takes an incoming data (or clock) signal, locks onto it using a phase-locked loop (PLL) circuit, and outputs a recovered clock. The recovered clock can be used as a timing reference for oscilloscopes or BERTs.

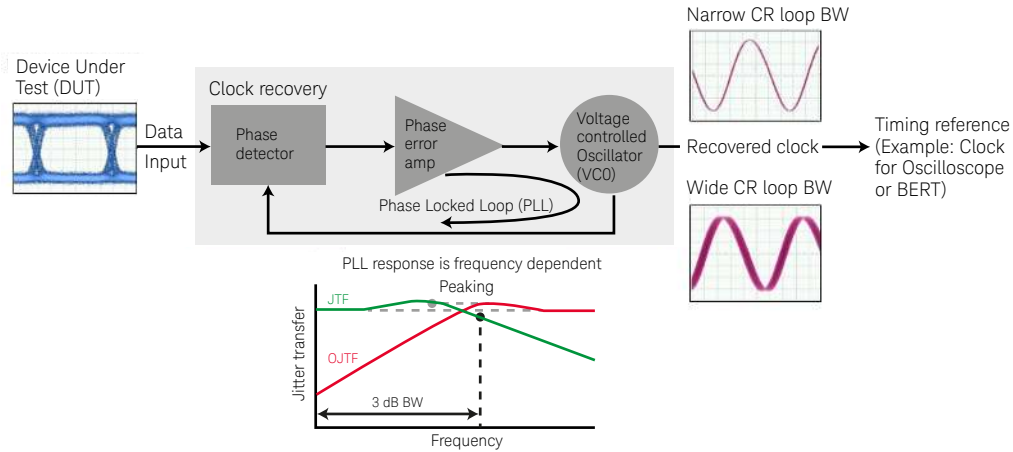

Figure 2. Clock recovery can be used to extract a timing reference signal from an incoming data signal. The amount of jitter on the recovered clock is determined by the loop bandwidth of the PLL.

Standards typically specify loop order, bandwidth, and peaking, all of which determines how much jitter on the incoming signal will appear on the recovered clock (also known as the jitter transfer function, or JTF). Users can configure the FlexDCA graphical user interface (GUI) to adjust these parameters and ensure standards-compliant clock recovery (often referred to as a “golden PLL”).

## Why Use Clock Recovery?

### Standards compliance

To comply with standards such as IEEE 802.3 Ethernet, Fibre Channel, or the Optical Interworking Forum – Common Electrical Interface (OIF-CEI), clock recovery must be used when performing measurements such as jitter, eye width, and/or eye height.

### Clock-less devices

Another reason to use clock recovery is when a clock or trigger signal is not provided by the device under test (DUT), but a clock is required to trigger an oscilloscope, or the error detector in a BERT.

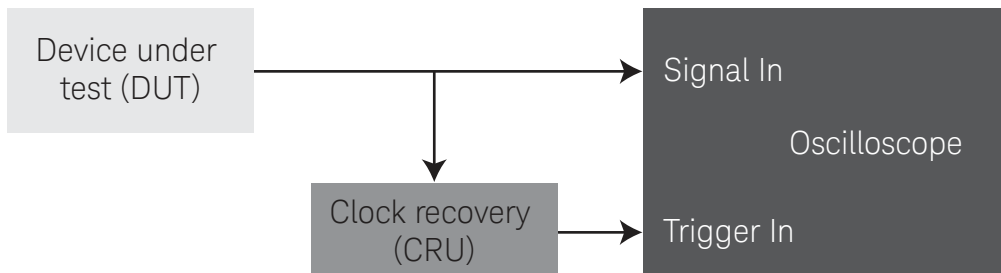

Figure 3. Clock recovery provides a compliant trigger signal for use by an oscilloscope or BERT.

## Electrical Clock Recovery

The N1076A and N1076B provide instrument-grade clock recovery on electrical signals up to 64 Gb/s. Adjustable loop bandwidth and peaking ensures standards-compliant clock recovery capability. The N1076A and N1076B are controlled via a USB connection to an 86100D DCA-X mainframe, or to a standalone PC running N1010A FlexDCA software.



Figure 4. The N1076A and N1076B clock recovery solutions.

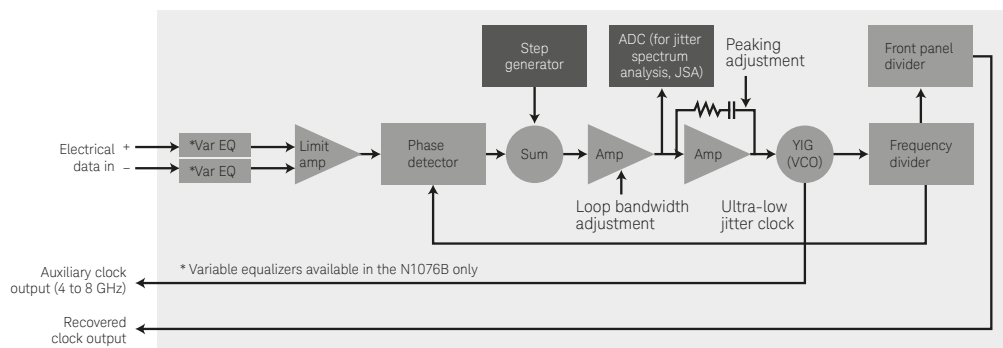

Figure 5. As shown in this block diagram, the N1076A and N1076B recover clock signals from NRZ and PAM4 input signals, and provide jitter analysis capability (Option JSA) for additional insight and measurement accuracy.

### Accurate clock recovery for high-speed applications

- Recovers clock from data streams up to 64 Gb/s (N1076B Option 264)
- Supports both NRZ and PAM4 signal types
- Tolerates small input signals
- Provides an auxiliary clock output signal with intrinsic random jitter as low as 100 fs RMS for accurate measurements. Use to connect to 86100D DCA-X precision timebase (PTB) input
- Optional jitter spectrum analysis (Option JSA) feature provides additional insight into jitter and allows users to perform jitter measurements using an “ideal” clock recovery model
- Connects to an 86100D DCA-X or PC via a USB 2.0 interface

## Optical/Electrical Clock Recovery

The N1077A and N1078A provide instrument-grade clock recovery with adjustable loop bandwidth and peaking on both electrical and optical signals up to 64 GBd. Both are via a USB connection to an 86100D DCA-X mainframe, or to a standalone PC running N1010A FlexDCA software.

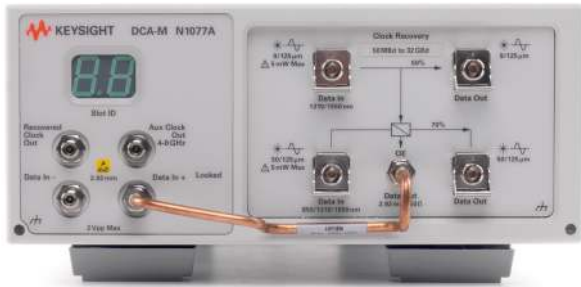

The N1077A supports both multimode and single-mode operation, can be ordered with integrated 70-30 multimode and 50-50 single-mode splitters as shown (option SMS) or with no splitter (option SXT) and operates up to 32.8 GBd.



The N1078A supports single-mode operation only, can be ordered with an integrated 50-50 single-mode splitter as shown (option S50) or with no splitter (option SXT) and operates up to 64 GBd.

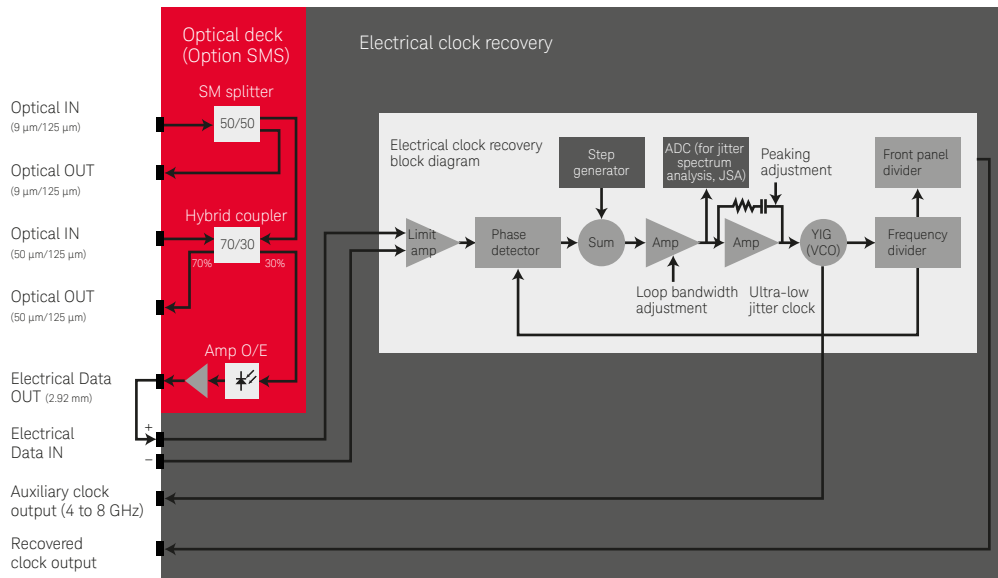

Figure 6. The N1077A with Option SMS combines an integrated optical deck (a splitter, bulk-optics coupler, and an amplified O/E) with an instrument-grade electrical clock recovery circuit.

## Optical/Electrical Clock Recovery (Continued)

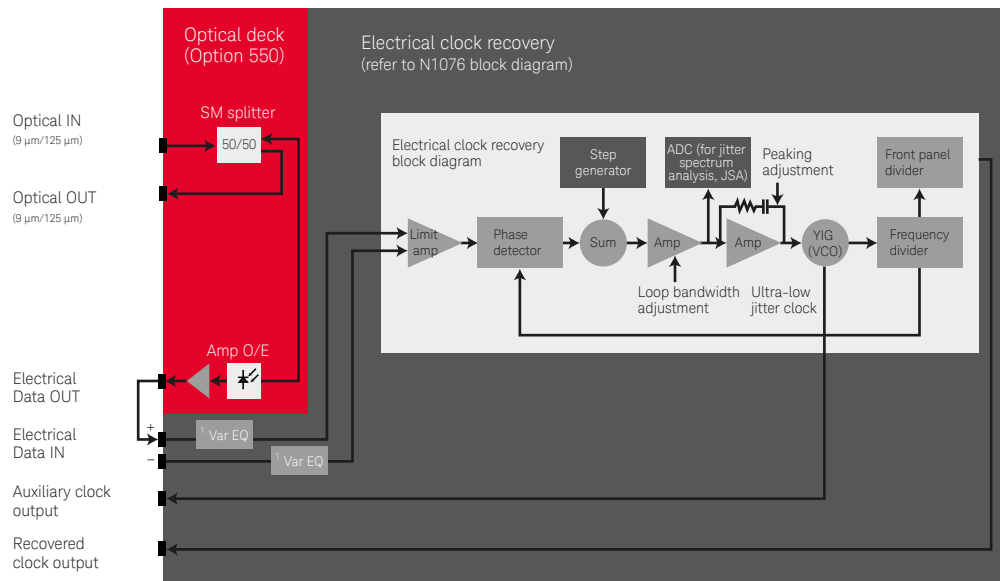

Figure 7. The N1078A with Option S50 combines an integrated 50-50 splitter and an amplified O/E with an instrument grade clock recovery circuit.

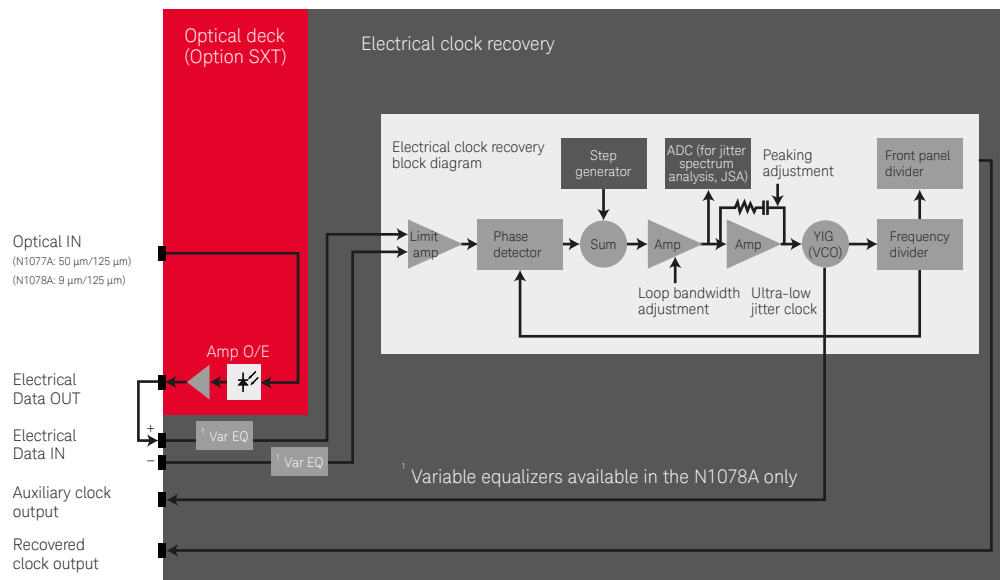

Figure 8. The N1077A and N1078A with Option SXT combine an integrated amplified O/E with an instrument-grade electrical clock recovery circuit. The user supplies an external optical splitter as necessary (10-90, 20-80, 30-70, 50-50, etc.).

Accurate, convenient solution for recovering clock signals from high-speed optical communication signals

- Optional integrated splitter/coupler extracts a portion of the optical test signal using a built-in coupler. Main optical signal is returned to the front panel. Converts the tapped optical signal to an electrical signal using an amplified O/E for greater sensitivity
- Recovers clock from data streams up to 64 GBd N1078A: (N1078A option 264)
- Supports both NRZ and PAM4 signal types
- Provides an easy method for using the electrical clock recovery solution with optical signals

## Characterize Next-generation Receivers and Transmitters

The wide data-rate range of Keysight's clock recovery solutions allows testing of standards like 100/400G Ethernet and 64 GFC, while covering existing lower speed standards.

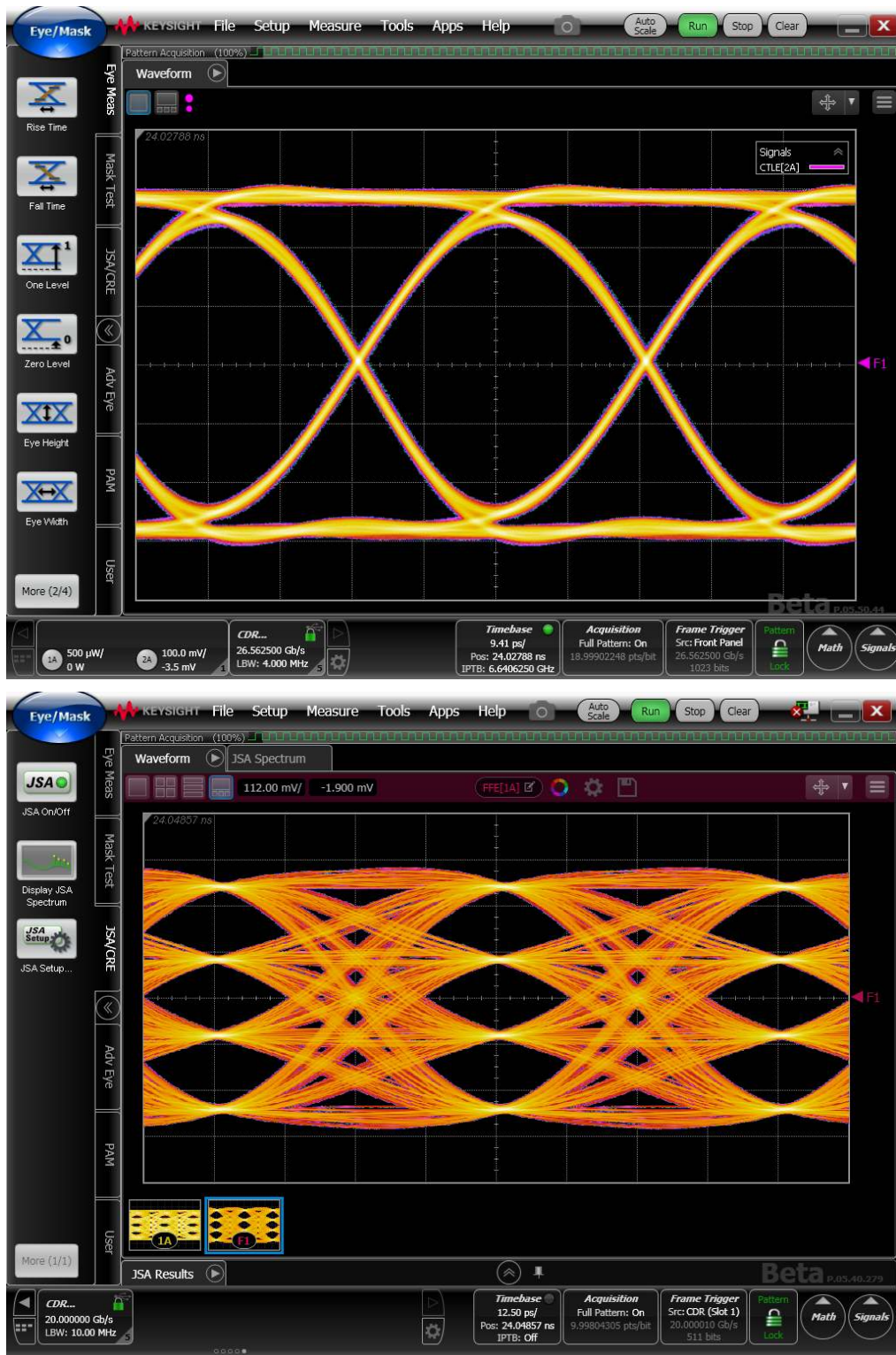

Figure 10. The N107x provides clock recovery capabilities for NRZ (top) and PAM4 (bottom) signals.

# Characterize Next-generation Receivers and Transmitters (Continued)

## Recover clocks or clean-up clocks

The N107x provides clock signals for BERTs or oscilloscopes when access to appropriate clock signals from the DUT is not possible. It can also act as a clean-up PLL for existing clocks with excessive intrinsic jitter to allow accurate measurements.

## Measure the real performance of clock-less devices

Accurate transmitter measurements are possible because of low intrinsic jitter, paired with tunable loop bandwidth, selectable peaking, and good sensitivity. The N107x's auxiliary clock output provides ultra-low intrinsic random jitter of less than 100 fs RMS, making it the ideal companion for sampling scopes equipped with a precision time base.

## Perform more accurate jitter measurements and gain greater insight into the root cause(s) of jitter

Jitter spectrum analysis (Option JSA) integrates a step generator and a low-noise, 14-bit ADC into the clock recovery design (see Figures 4, 6, and 8). The step generator and ADC characterize the clock recovery PLL in real-time, providing FlexDCA with the information that is necessary to calculate jitter at the input to the instrument. JSA uses this information to:

- Optimize the accuracy of random jitter measurements performed by 86100D-200 Jitter mode
- Emulate an "ideal" software clock recovery (CR) response; implement Golden PLL per standards
- Analyze the jitter spectrum of clock and data signals using jitter magnitude vs. frequency graphs
- View the spectral distribution of low-frequency jitter and isolate jitter components
- Perform band limited (integrated) TJ/DJ/RJ measurements; user-specified start/stop frequencies



Figure 11. Jitter spectrum analysis (N107xA Option JSA) optimizes Jitter Mode (86100D Option 200) accuracy, measures low-frequency jitter (phase noise), and provides insight into the root cause(s) of jitter.

# Characterize Next-generation Receivers and Transmitters (Continued)

## Easily control all settings

The N107x clock recovery instrument is controlled via a rear-panel USB connection to an 86100D DCA-X mainframe, or to a standalone PC (Win7) running Keysight Technologies N1010A FlexDCA software (no license required for CR control).



Figure 12. Easily configure the N107x clock recovery data rate, loop bandwidth, and peaking using the N1010A FlexDCA user interface running on an 86100D DCA-X mainframe or standalone PC.

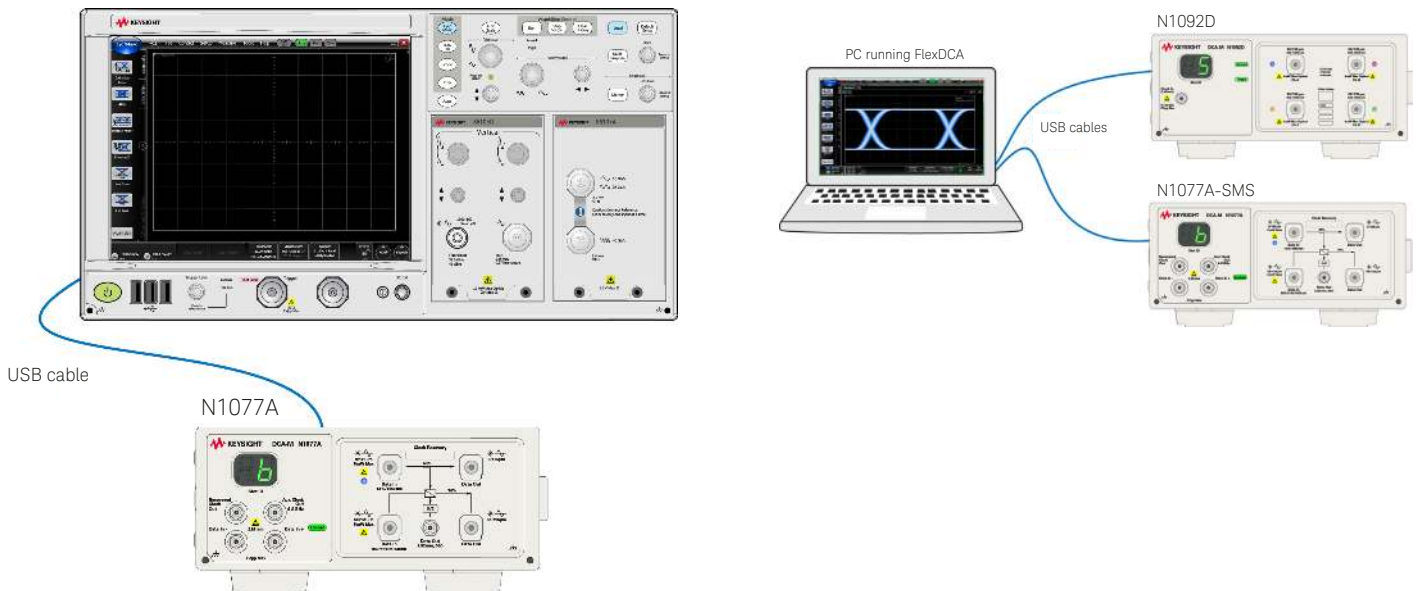

Figure 13. The N107x clock recovery instrument is controlled via a rear-panel USB connection to an 86100D DCA-X mainframe (left), or to a standalone PC (right) running the N1010A FlexDCA user interface.

## Application Example

### Clock recovery for sampling scope with high-bandwidth sampling heads and precision time base

Sampling scopes are the ideal choice for transmitter characterization when high-bandwidth, low noise floor and low intrinsic jitter are required. The N107x, with its ultra-low jitter auxiliary clock output, provides a clean sine wave for a precision time-base module or integrated precision timebase enabling the most accurate measurements (precision timebase is not required). The main recovered clock output, with its divide stages, triggers the front panel trigger input. For additional Application Examples see the Keysight N107X-Series Clock Recovery DCA-Ms User's Guide, N1076-90003. Go to [www.keysight.com/find/N1077A](http://www.keysight.com/find/N1077A) and click the Resource Center tab.

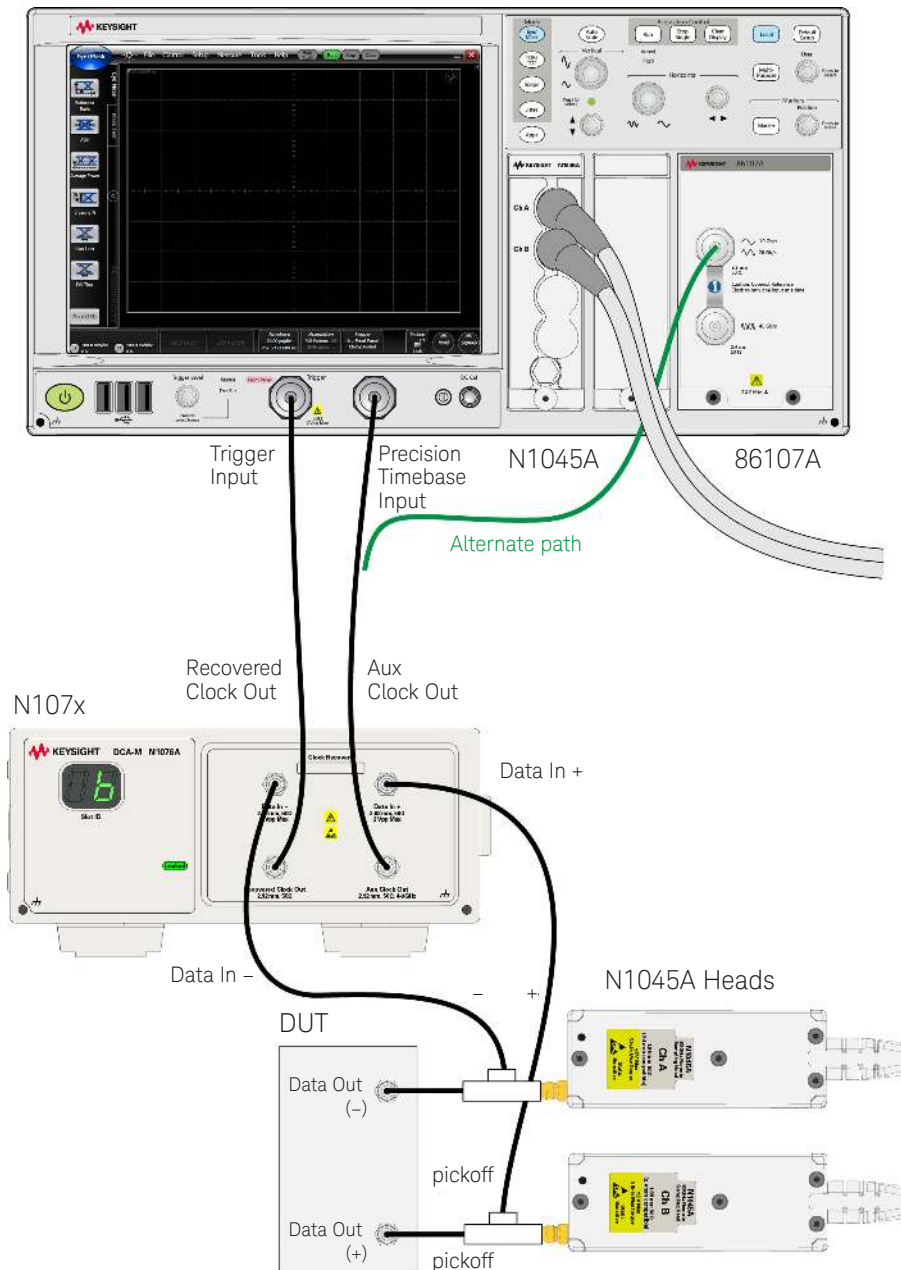

Figure 14. Connection diagram showing an N107x connected to an 86100D DCA-X and remote head modules using high-bandwidth electrical pick-offs (optional accessory).

# N1076A Specifications

Electrical Data Input (+/-)	Option 216	Option 232
Data rate input range	50 MBd to 16 GBd <i>50 MBd to 32 GBd (characteristic)</i>	50 MBd to 32 GBd <i>50 MBd to 32.8 GBd (characteristic)</i>
Minimum input level to acquire lock	30 mVpp (for rates $\leq$ 27 GBd) 35 mVpp (for rates $>$ 27 GBd) <i>25 mVpp at 25.78125 Gbd (characteristic)</i>	
Input voltage levels (min/max)	$\pm$ 2.2 Vpp (maximum)	
Minimum transition density	20%	
Interface	Differential or single-ended, AC coupled, 50 $\Omega$	
Connector type	2.92 mm (f)	

Recovered Clock Output	
Clock output range	50 MHz to 16 GHz
Recovered clock random jitter	220 fs max at $\geq$ 2 Gbd, <i>130 fs at 16 GHz (characteristic)</i>
Loop bandwidth range	0.015 to 20 MHz
Loop bandwidth accuracy	$\pm$ 30% (characteristic)
Clock recovery peaking range	Up to 4 settings (dependent on loop BW)
Tracking range (includes SSC tracking)	$\pm$ 2500 ppm $\pm$ 0.25% (characteristic)
Acquisition range	$\pm$ 5000 ppm (characteristic)
Auto relocking	Yes
Residual spread spectrum	<i>-84 dB <math>\pm</math> 3 dB at 33 kHz (characteristic)</i>
Phase noise accuracy	<i>30% (characteristic)</i>
Front panel recovered clock amplitude	$\geq$ 320 mVpp at 5 GHz
Front panel recovered clock divide ratio (user selectable)	1, 2, 4, 8, 16
Internal frequency counter accuracy	$\pm$ 10 ppm
Interface	Single-ended, AC coupled, 50 $\Omega$
Connector type	2.92 mm (f)

Aux Clock Output	
Output frequency	4 to 8 GHz
Output voltage	<i>550 mVpp (characteristic)</i>
Output jitter	<i>&lt; 50 fs RMS (characteristic)</i>
Interface	Single-ended, DC coupled, 50 $\Omega$
Connector type	2.92 mm (f)

Environmental Specifications		
Use	Indoor	
Temperature	Operating	10C to +40C (50°F to +104°F)
	Non-operating	-40C to +70C (-40°F to +158°F)
Altitude (Operating)	Up to 4,600 meters (15,000 ft)	
Maximum Relative Humidity	80% for temperatures up to 31°C decreasing linearly to 50% relative humidity at 40°C	
Line Power		100/120Vac, 50/60/400 Hz
		220/240Vac, 50/60 Hz
		290 Watts Maximum
	The products can operate with mains supply voltage fluctuations up to $\pm$ 10% of the nominal voltage.	
Volts-Amperes (VA)		<i>48 VA (characteristic)</i>
Weight		<i>6.0 kg (13.2 lb) (characteristic)</i>
Dimensions	Without front connectors and rear feet	88.26 mm H x 207.40 mm W x 485 mm D (3.48 inch x 8.17 inch x 19.01 inch)
	With front connectors and rear feet	103.31 mm H x 219.56 mm W x 517.80 mm D (4.07 inch x 8.64 inch x 20.39 inch)
	With front cover and rear feet	110.18 mm H x 219.56 mm W x 550.71 mm D (4.34 inch x 8.64 inch x 21.68 inch)

# N1076B Specifications

Electrical Data Input (+/-)	Specifications
<b>Data rate input range</b>	
Option 264	125 MBd to 64 GBd, <i>125 MBd to 65.6 GBd (characteristic)</i>
Option 232	125 MBd to 32 GBd, <i>125 MBd to 32.8 GBd (characteristic)</i>
Option 216	125 MBd to 16 GBd, <i>125 MBd to 16.4 GBd (characteristic)</i>
<b>Minimum input level to acquire lock (NRZ &amp; PAM4, single-ended, open eye)</b>	
Option 264	30 mV pp (rate ≤ 53.125 GBd) 60 mV pp (rate > 53.125 GBd) <i>10 mV pp at 10.3125 GBd (characteristic)</i> <i>10 mV pp at 26.56 GBd (characteristic)</i> <i>20 mV pp at 53.125 GBd (characteristic)</i> <i>25 mV pp at 56 GBd (characteristic)</i> <i>50 mV pp at 64 GBd (characteristic)</i>
Option 232	30 mV pp <i>10 mV pp at 10.3125 GBd (characteristic)</i> <i>10 mV pp at 26.56 GBd (characteristic)</i>
Option 216	30 mV pp <i>10 mV pp at 10.3125 GBd (characteristic)</i>
<b>Minimum input level to acquire lock (PAM4, closed eye)</b>	
Option 264	<i>50 mV pp at 26.56 GBd with 20 dB channel loss at 13.28 GHz (characteristic)</i> <i>50 mV pp at 53.125 GBd with 10 dB channel loss at 26.56 GHz (characteristic)</i>
Option 232	<i>50 mV pp at 26.56 GBd with 20 dB channel loss at 13.28 GHz (characteristic)</i>
Option 216	NA
<b>Other</b>	
Input Voltage Levels (min/max)	±500 mV (maximum)
Minimum transition density	20%
Interface	Differential or single-ended, DC coupled, 50 Ω
Connector Type	2.92 mm (f)

## N1076B Specifications (Continued)

<b>Recovered Clock Output</b>		<b>Option 216</b>	<b>Option 232</b>	<b>Option 264</b>
Clock Output Range		62.5 MHz to 16 GHz <i>62.5 MHz to 16.4 GHz (characteristic)</i>	62.5 MHz to 32 GHz <i>62.5 MHz to 32.8 GHz (characteristic)</i>	
Recovered Clock Random Jitter		280 fs maximum at $\geq 2.5$ GHz <i>180 fs at 10 GHz (characteristic)</i>		280 fs maximum at $\geq 2.5$ GHz <i>150 fs at 26 GHz (characteristic)</i>
Loop Bandwidth Range (user selectable)		0.015 to 20 MHz		
Loop Bandwidth Accuracy		$\pm 30\%$ (characteristic)		
Clock Recovery Peaking Range		Up to 4 settings (dependent on loop BW)		
Tracking Range (includes spreadspectrum tracking)		$\pm 2500$ ppm ( $\pm 0.25\%$ ) (characteristic)		
Acquisition Range				
Standard Signals		$\pm 300$ ppm (characteristic)		
Spread Spectrum Signals		$\pm 5000$ ppm (characteristic)		
Auto Relocking		Yes		
Phase Noise Accuracy		$\pm 30\%$ (characteristic)		
Front Panel Recovered Clock Amplitude		$\geq 200$ mV pp <i>450 mV pp @ 5 GHz (characteristic)</i>	$\geq 200$ mV pp <i>450 mV pp @ 5 GHz (characteristic)</i> <i>300 mV pp @ 26.56 GHz (characteristic)</i>	
Front Panel Recovered Clock Divide Ratio (user selectable)		1, 2, 4, 8, 16, 32		
Internal Frequency Counter Accuracy		$\pm 10$ ppm		
Interface		Single-ended, DC coupled, 50 $\Omega$		
Connector Type		2.92 mm (f)		
<b>Aux Clock Output <sup>1</sup></b>				
Output frequency		8 GHz to 16 GHz		
Output voltage		<i>700 mVpp (characteristic)</i>		
Output jitter		<i>&lt; 50 fs RMS (characteristic)</i>		
Interface		Single-ended, DC coupled, 50 $\Omega$		
Connector type		2.92 mm (f)		
1. Recovered clock to Aux Clock ratio is always 2 <sup>N</sup>				
<b>Environmental Specifications</b>				
Use		Indoor		
Temperature	Operating	10C to +40C (50°F to +104°F)		
	Non-operating	-40C to +70C (-40°F to +158°F)		
Altitude (Operating)		Up to 4,600 meters (15,000 ft)		
Maximum Relative Humidity		Type tested at 95% relative humidity, +40 degrees C (noncondensing)		
Line Power		100/120Vac, 50/60/400 Hz		
		220/240Vac, 50/60 Hz		
		290 Watts Maximum		
		The products can operate with mains supply voltage fluctuations up to $\pm 10\%$ of the nominal voltage.		
Volts-Amperes (VA)		<i>48 VA (characteristic)</i>		
Weight		<i>6.17 kg (13.6 lb) (characteristic)</i>		
Dimensions	Without front connectors and rear feet	88.26 mm H x 207.40 mm W x 485 mm D (3.48 inch x 8.17 inch x 19.01 inch)		
	With front connectors and rear feet	103.31 mm H x 219.56 mm W x 517.80 mm D (4.07 inch x 8.64 inch x 20.39 inch)		
	With front cover and rear feet	110.18 mm H x 219.56 mm W x 550.71 mm D (4.34 inch x 8.64 inch x 21.68 inch)		

# N1077A Specifications

Electrical Data Input (+/-)	Option 216	Option 232
Data rate input range	50 MBd to 16 GBd <i>50 MBd to 16.4 GBd (characteristic)</i>	50 MBd to 32 GBd <i>50 MBd to 32.8 GBd (characteristic)</i>
Minimum input level to acquire lock	30 mVpp (for rates $\leq$ 27 GBd) 35 mVpp (for rates $>$ 27 GBd) <i>25 mVpp at 25 Gbd (characteristic)</i>	
Input voltage levels (min/max)	$\pm$ 2.2 Vpp (maximum)	
Minimum transition density	20%	
Interface	Differential or single-ended, AC coupled, 50 $\Omega$	
Connector type	2.92 mm (f)	

Recovered Clock Output	Description
Clock output range	50 MHz to 16 GHz
Recovered clock random jitter	220 fs max at $\geq$ 2 Gbd, <i>130 fs at 16 GHz (characteristic)</i>
Loop Bandwidth Range (user selectable)	0.015 to 20 MHz
Loop bandwidth accuracy	$\pm$ 30% (characteristic)
Clock recovery peaking range	Up to 4 settings (dependent on loop BW)
Tracking Range (includes spread-spectrum tracking)	$\pm$ 2500 ppm $\pm$ 0.25% (characteristic)
Acquisition range	$\pm$ 5000 ppm (characteristic)
Auto relocking	Yes
Residual spread spectrum	<i>-84 dB <math>\pm</math> 3 dB at 33 kHz (characteristic)</i>
Phase noise accuracy	<i>30% (characteristic)</i>
Front panel recovered clock amplitude	$\geq$ 320 mVpp at 5 GHz
Front Panel Recovered Clock Divide Ratio (user selectable)	1, 2, 4, 8, 16
Internal frequency counter accuracy	$\pm$ 10 ppm
Interface	Single-ended, AC coupled, 50 $\Omega$
Connector type	2.92 mm (f)

Aux Clock Output	
Output frequency	4 GHz to 8 GHz
Output voltage	<i>550 mVpp (characteristic)</i>
Output jitter	<i>&lt; 50 fs RMS (characteristic)</i>
Interface	Single-ended, DC coupled, 50 $\Omega$
Connector type	2.92 mm (f)

Optical Data Input/Output	9/125 $\mu$ m	50/125 $\mu$ m
Optical Data Rate Range	Determined by Option 216/232	
Internal Split Ratio (Optical Out / Internal O/E)	50/50 (nominal)	70/30 (nominal)
Optical Signal Type/Mode	Single-Mode only	Single-Mode or Multimode
Wavelength Range	1310 nm (1260 nm to 1360 nm) 1550 nm (1490 nm to 1600 nm)	850 nm (830 nm to 1360 nm) 1310 nm (1260 nm to 1360 nm) 1550 nm (1490 nm to 1600 nm)
Insertion Loss (Option SMS)	4.75 dB <i>4.0 dB (characteristic)</i>	4.0 dB <i>2.8 dB (characteristic)</i>
Return Loss	<i>18 dB (characteristic)</i>	<i>16 dB (characteristic)</i>
<b>Minimum Optical Modulation Amplitude (OMA) to achieve lock (Option SMS)</b>		
850 nm		260 $\mu$ W <i>170 <math>\mu</math>W at 25 Gbps (characteristic)</i> <i>90 <math>\mu</math>W at 10 Gbps (characteristic)</i>
1310 nm/1550 nm	200 $\mu$ W <i>100 <math>\mu</math>W at 25 Gbps (characteristic)</i> <i>60 <math>\mu</math>W at 10 Gbps (characteristic)</i>	200 $\mu$ W <i>100 <math>\mu</math>W at 25 Gbps (characteristic)</i> <i>60 <math>\mu</math>W at 10 Gbps (characteristic)</i>

## N1077A Specifications (Continued)

Optical Data Input/Output		9/125 $\mu\text{m}$	50/125 $\mu\text{m}$
<b>Minimum Optical Modulation Amplitude (OMA) to achieve lock (Option SXT)</b>			
850 nm			90 $\mu\text{W}$ <i>53 <math>\mu\text{W}</math> at 25 Gbps (characteristic)</i> <i>33 <math>\mu\text{W}</math> at 10 Gbps (characteristic)</i>
1310 nm/1550 nm		80 $\mu\text{W}$ <i>43 <math>\mu\text{W}</math> at 25 Gbps (characteristic)</i> <i>23 <math>\mu\text{W}</math> at 10 Gbps (characteristic)</i>	80 $\mu\text{W}$ <i>43 <math>\mu\text{W}</math> at 25 Gbps (characteristic)</i> <i>23 <math>\mu\text{W}</math> at 10 Gbps (characteristic)</i>
Maximum Input Power		8 mW	8 mW
Maximum Non-destruct Peak		8 mW	8 mW
<b>Optical-to-Electrical Conversion Gain</b>			
Option SMS		<i>180 V/W (characteristic)</i>	<i>120 V/W (characteristic)</i>
Option SXT		<i>550 V/W (characteristic)</i>	<i>360 V/W (characteristic)</i>
Optical Input/Output Connector Type		FC/PC 9/125 $\mu\text{m}$	FC/PC 50/125 $\mu\text{m}$
Electrical O/E - Output Connector Type		2.92 mm (f)	2.92 mm (f)
<b>Environmental Specifications</b>			
Use		Indoor	
Temperature	Operating	10C to +40C (50°F to +104°F)	
	Non-operating	-40C to +70C (-40°F to +158°F)	
Altitude (Operating)		Up to 4,600 meters (15,000 ft)	
Maximum Relative Humidity		80% for temperatures up to 31°C decreasing linearly to 50% relative humidity at 40°C	
Line Power		100/120Vac, 50/60/400 Hz	
		220/240Vac, 50/60 Hz	
		290 Watts Maximum	
		The products can operate with mains supply voltage fluctuations up to $\pm 10\%$ of the nominal voltage.	
Volts-Amperes (VA)		<i>52 VA (characteristic)</i>	
Weight	N1077A-SMS	<i>6.3 kg (13.8 lb) (characteristic)</i>	
	N1077A-SXT	<i>6.1 kg (13.4 lb) (characteristic)</i>	
Dimensions	Without front connectors and rear feet	88.26 mm H x 207.40 mm W x 485 mm D (3.48 inch x 8.17 inch x 19.01 inch)	
	With front connectors and rear feet	103.31 mm H x 219.56 mm W x 517.80 mm D (4.07 inch x 8.64 inch x 20.39 inch)	
	With front cover and rear feet	110.18 mm H x 219.56 mm W x 550.71 mm D (4.34 inch x 8.64 inch x 21.68 inch)	

# N1078A Specifications

Electrical Data Input (+/-)	Specification
<b>Data rate input range</b>	
Option 264	125 MBd to 64 GBd, <i>125 MBd to 65.6 GBd (characteristic)</i>
Option 253	53 GBd to 58 GBd
Option 232	125 MBd to 32 GBd, <i>125 MBd to 32.8 GBd (characteristic)</i>
Option 225	25 GBd to 29 GBd
Option 216	125 MBd to 16 GBd, <i>125 MBd to 16.4 GBd (characteristic)</i>
<b>Minimum input level to acquire lock (NRZ &amp; PAM4, single-ended, open eye)</b>	
Option 264	30 mV pp (rate $\leq$ 53.125 GBd) 60 mV pp (rate > 53.125 GBd) <i>10 mV pp at 10.3125 GBd (characteristic)</i> <i>10 mV pp at 26.56 GBd (characteristic)</i> <i>20 mV pp at 53.125 GBd (characteristic)</i> <i>25 mV pp at 56 GBd (characteristic)</i> <i>50 mV pp at 64 GBd (characteristic)</i>
Option 253	60 mV pp <i>20 mV pp at 53.125 GBd (characteristic)</i> <i>25 mV pp at 56 GBd (characteristic)</i>
Option 232	30 mV pp <i>10 mV pp at 10.3125 GBd (characteristic)</i> <i>10 mV pp at 26.56 GBd (characteristic)</i>
Option 225	30 mV pp <i>10 mV pp at 26.56 GBd (characteristic)</i>
Option 216	30 mV pp <i>10 mV pp at 10.3125 GBd (characteristic)</i>
<b>Minimum input level to acquire lock (PAM4, closed eye)</b>	
Option 264	<i>50 mV pp at 26.56 GBd with 20 dB channel loss at 13.28 GHz (characteristic)</i> <i>50 mV pp at 53.125 GBd with 10 dB channel loss at 26.56 GHz (characteristic)</i>
Option 253	<i>50 mV pp at 53.125 GBd with 10 dB channel loss at 26.56 GHz (characteristic)</i>
Options 232, 225	<i>50 mV pp at 26.56 GBd with 20 dB channel loss at 13.28 GHz (characteristic)</i>
Option 216	NA
<b>Other</b>	
Input Voltage Levels (min/max)	$\pm$ 500 mV (maximum)
Minimum transition density	20%
Interface	Differential or single-ended, DC coupled, 50 $\Omega$
Connector Type	2.92 mm (f)
<b>Optical Data Input/Output</b>	
<b>Data rate input range</b>	
Option 264	125 MBd to 64 GBd, <i>125 MBd to 65.6 GBd (characteristic)</i>
Option 253	53 GBd to 58 GBd
Option 232	125 MBd to 32 GBd, <i>125 MBd to 32.8 GBd (characteristic)</i>
Option 225	25 GBd to 29 GBd
Option 216	125 MBd to 16 GBd, <i>125 MBd to 16.4 GBd (characteristic)</i>
Internal Split Ratio (Option S50) (Optical Out / Internal O/E)	50/50 (nominal)
Optical Signal Type/Mode	Single-Mode only
Wavelength Range	1260 nm to 1620 nm. Tested at 1310 nm and 1550 nm.
Insertion Loss (Option S50)	4.75 dB, <i>3.5 dB (characteristic)</i>
Return Loss	<i>16 dB (characteristic)</i>
Maximum Input Power	8 mW (option S50) 4 mW (option SXT)

## N1078A Specifications (Continued)

<b>Optical-to-Electrical Conversion Gain</b>				
Options 264, 253	125 V/W @ 53.125 GBd (option S50) (characteristic) 250 V/W @ 53.125 GBd (option SXT) (characteristic)			
Options 232, 225, 264	120 V/W @ 26.56 GBd (option S50) (characteristic) 240 V/W @ 26.56 GBd (option SXT) (characteristic)			
Option 216, 232, 264	110 V/W @ 10.3125 GBd (option S50) (characteristic) 220 V/W @ 10.3125 GBd (option SXT) (characteristic)			
Optical Input/Output Connector Type	FC/PC 9/125 $\mu$ m			
Electrical O/E - Output Connector Type	2.92 mm (f)			
<b>Minimum Optical Modulation Amplitude (OMA) to achieve lock (Option S50)</b>				
<b>NRZ and PAM4 (OMA) 1310 nm/1550 nm</b>				
Option 264	200 $\mu$ W (rate $\leq$ 53.125 GBd) 400 $\mu$ W (53.125 GBd < rate $\leq$ 59 GBd) 60 $\mu$ W at 10.3125 GBd (characteristic) 80 $\mu$ W at 26.56 GBd (characteristic) 80 $\mu$ W at 53.125 GBd (characteristic) 150 $\mu$ W at 56 GBd (characteristic) 300 $\mu$ W at 64 GBd (characteristic)			
Option 253	400 $\mu$ W 80 $\mu$ W at 53.125 GBd (characteristic) 150 $\mu$ W at 56 GBd (characteristic)			
Option 232	200 $\mu$ W 60 $\mu$ W at 10.3125 GBd (characteristic) 80 $\mu$ W at 26.56 GBd (characteristic)			
Option 225	200 $\mu$ W 80 $\mu$ W at 26.56 GBd (characteristic)			
Option 216	200 $\mu$ W 60 $\mu$ W at 10.3125 GBd (characteristic)			
<b>PAM4 Stressed Eye 1310 nm/1550 nm (characteristic)</b>				
<b>(Clock recovery locks under these conditions)</b>				
	<b>Baud Rate</b>	<b>Pattern</b>	<b>Outer OMA</b>	<b>TDECQ</b>
Option 264	26.56 GBd	SSPRQ	-5.1 dBm	~ 3.4 dB
	53.125 GBd	SSPRQ	-0.81 dBm	~ 3.4 dB
Option 253	53.125 GBd	SSPRQ	-0.81 dBm	~ 3.4 dB
Options 225, 232	26.56 GBd	SSPRQ	-5.1 dBm	~ 3.4 dB

## N1078A Specifications (Continued)

<b>Minimum Optical Modulation Amplitude (OMA) to achieve lock (Option SXT)</b>				
<b>NRZ and PAM4 (OMA) 1310 nm/1550 nm</b>				
Option 264	100 $\mu$ W (rate $\leq$ 53.125 GBd) 200 $\mu$ W (53.125 GBd < rate $\leq$ 59 GBd) <i>30 <math>\mu</math>W at 10.3125 GBd (characteristic)</i> <i>40 <math>\mu</math>W at 26.56 GBd (characteristic)</i> <i>40 <math>\mu</math>W at 53.125 GBd (characteristic)</i> <i>75 <math>\mu</math>W at 56 GBd (characteristic)</i> <i>150 <math>\mu</math>W at 64 GBd (characteristic)</i>			
Option 253	200 $\mu$ W <i>40 <math>\mu</math>W at 53.125 GBd (characteristic)</i> <i>75 <math>\mu</math>W at 56 GBd (characteristic)</i>			
Option 232	100 $\mu$ W <i>30 <math>\mu</math>W at 10.3125 GBd (characteristic)</i> <i>40 <math>\mu</math>W at 26.56 GBd (characteristic)</i>			
Option 225	100 $\mu$ W <i>40 <math>\mu</math>W at 26.56 GBd (characteristic)</i>			
Option 216	100 $\mu$ W <i>30 <math>\mu</math>W at 10.3125 GBd (characteristic)</i>			
<b>PAM4 Stressed Eye 1310 nm/1550 nm (characteristic)</b>				
<b>(Clock recovery locks under these conditions)</b>				
	<b>Baud Rate</b>	<b>Pattern</b>	<b>Outer OMA</b>	<b>TDECQ</b>
Option 264	26.56 GBd	SSPRQ	-5.1 dBm	~ 3.4 dB
	53.125 GBd	SSPRQ	-0.81 dBm	~ 3.4 dB
Option 253	53.125 GBd	SSPRQ	-0.81 dBm	~ 3.4 dB
Options 225, 232	26.56 GBd	SSPRQ	-5.1 dBm	~ 3.4 dB
<b>Recovered Clock Output</b>				
<b>Clock Output Range</b>				
Option 264	62.5 MHz to 32 GHz <i>62.5 MHz to 32.8 GHz (characteristic)</i>			
Option 253	26.5 GHz to 29 GHz and subrates			
Option 232	62.5 MHz to 32 GHz <i>62.5 MHz to 32.8 GHz (characteristic)</i>			
Option 225	25 GHz to 29 GHz and subrates			
Option 216	62.5 MHz to 16 GHz <i>62.5 MHz to 16.4 GHz (characteristic)</i>			
<b>Recovered Clock Random Jitter</b>				
Options 225, 232, 253, 264	280 fs maximum ( $\geq$ 2.5 GHz) <i>150 fs at 26 GHz (characteristic)</i>			
Option 216	280 fs maximum ( $\geq$ 2.5 GHz) <i>180 fs at 10 GHz (characteristic)</i>			
Loop Bandwidth Range (user selectable)	0.015 to 20 MHz			
Loop Bandwidth Range (user selectable)	$\pm$ 30% (characteristic)			
Clock Recovery Peaking Range	Up to 4 settings (dependent on loop BW)			
Tracking Range (includes spread-spectrum tracking)	$\pm$ 2500 ppm ( $\pm$ 0.25%) (characteristic)			
Acquisition Range				
Standard Signals	$\pm$ 300 ppm (characteristic)			
Spread Spectrum Signals	$\pm$ 5000 ppm (characteristic)			
Auto Relocking	Yes			
Phase Noise Accuracy	30% (characteristic)			

## N1078A Specifications (Continued)

<b>Front Panel Recovered Clock Amplitude</b>		
Options 225, 232, 253, 264	≥200 mV pp <i>450 mV pp @ 5 GHz (characteristic)</i> <i>300 mV pp @ 26.56 GHz (characteristic)</i>	
Option 216	≥200 mV pp <i>450 mV pp @ 5 GHz (characteristic)</i>	
Front Panel Recovered Clock Divide Ratio (user selectable)	1, 2, 4, 8, 16, 32	
Internal Frequency Counter Accuracy	±10 ppm	
Interface	Single-ended, DC coupled, 50 Ω	
Connector Type	2.92 mm (f)	
<b>Aux Clock Output <sup>1</sup></b>		
Output frequency	8 GHz to 16 GHz	
Output voltage	<i>700 mV pp @ 13.28 GHz (characteristic)</i>	
Output jitter	<i>&lt; 50 fs RMS (characteristic)</i>	
Interface	Single-ended, DC coupled, 50 Ω	
Connector type	2.92 mm (f)	
1. Recovered clock to Aux Clock ratio is always 2 <sup>N</sup>		
<b>Environmental Specifications</b>		
Use	Indoor	
Temperature	Operating	10C to +40C (50°F to +104°F)
	Non-operating	-40C to +70C (-40°F to +158°F)
Altitude (Operating)	Up to 4,600 meters (15,000 ft)	
Maximum Relative Humidity	Type tested at 95% relative humidity, +40 degrees C (non-condensing)	
Line Power	100/120Vac, 50/60/400 Hz	
	220/240Vac, 50/60 Hz	
	290 Watts Maximum	
	The product can operate with mains supply voltage fluctuations up to ±10% of the nominal voltage.	
Volts-Amperes (VA)	<i>52 VA (characteristic)</i>	
Weight	N1078A-S50	<i>6.4 kg (14.2 lb) (characteristic)</i>
	N1078A-SXT	<i>6.4 kg (14.2 lb) (characteristic)</i>
	Without front connectors and rear feet	88.26 mm H x 207.40 mm W x 485 mm D (3.48 inch x 8.17 inch x 19.01 inch)
Dimensions	With front connectors, jumper cable (Data Out to Data In +), and rear feet	103.31 mm H x 219.56 mm W x 532.8 mm D (4.07 inch x 8.64 inch x 20.97 inch)
	With front cover and rear feet	110.18 mm H x 219.56 mm W x 550.71 mm D (4.34 inch x 8.64 inch x 21.68 inch)

## Ordering Information

### N1076A electrical clock recovery

Model number	Description
N1076A	Electrical clock recovery
Baud rate (choose ONE)	Description
Option 216	Supported input rates: 50 MBaud to 16 GBd
Option 232	Supported input rates: 50 MBaud to 32 GBd
Advanced options	Description
Option JSA	Jitter spectrum analysis and clock recovery emulation
Optional accessories	Description
N1076A-CR1	Clock recovery phase matching kit for N1076A elec (re-order N1027A-76A) Kit includes cables, 18.2 ns delay line, two pick-offs, two 6 dB equalizers, and two 9 dB equalizers
N1076A-EQ6	Equalizer, 2.92 mm (m) to 2.92 mm (f), 6 dB (re-order N1027A-EQ6)
N1076A-EQ9	Equalizer, 2.92 mm (m) to 2.92 mm (f), 9 dB (re-order N1027A-EQ9)
N1076A-2P2	Microwave pick-off tee 2.4 mm connectors, matched pair (re-order N1027A-2P2)
N1076A-2P3	Microwave pick-off tee 2.92 mm connectors, matched pair (re-order N1027A-2P3)
N1076A-DC1	Assembly, delay cable, 18.2 ns
N1076A-1CM	Single instrument rack mount kit (re-order N1027A-1CM)
N1076A-1CN	Dual instrument side-by-side rack mount kit (re-order N1027A-1CN)
R1280A	Return to Keysight service center - warranty and service plan
R1282A	Return to Keysight service center - calibration plan

### N1076B electrical clock recovery

Model number	Description
N1076B	Electrical clock recovery
Baud rate (choose ONE)	Description
Option 216	Supported input rates: 125 MBaud to 16 GBd
Option 232	Supported input rates: 125 MBaud to 32 GBd
Option 264	Supported input rates: 125 MBaud to 64 GBd
Advanced options	Description
Option JSA	Jitter spectrum analysis and clock recovery emulation
Option EVA	Integrated variable equalizers on data + and data - inputs
Optional accessories <sup>1</sup>	Description
N1076B-CR1	Clock recovery phase matching kit for N1076B
N1076B-2P1	Microwave pick-off tee 1 mm connectors, matched pair
N1076B-2P8	Microwave pick-off tee 1.85 mm connectors, matched pair
N1076B-2P2	Microwave pick-off tee 2.4 mm connectors, matched pair
N1076B-2P3	Microwave pick-off tee 2.92 mm connectors, matched pair
N1076B-EQ3	Equalizer, 2.92 mm (m) to 2.92 mm (f), 3 dB
N1076B-EQ6	Equalizer, 2.92 mm (m) to 2.92 mm (f), 6 dB
N1076B-EQ9	Equalizer, 2.92 mm (m) to 2.92 mm (f), 9 dB
N1076B-1CM	Single instrument rack mount kit
N1076B-1CN	Dual instrument side-by-side rack mount kit (re-order N1027A-1CN)
R1280A	Return to Keysight service center - warranty and service plan
R1282A	Return to Keysight service center - calibration plan

1. Some accessories may not be available at launch.

## N1077A optical/electrical clock recovery

Model number	Description
N1077A	Optical/electrical clock recovery
Baud rate (choose ONE)	Description
Option 216	Supported input rates: 50 MBd to 16 GBd
Option 232	Supported input rates: 50 MBd to 32 GBd
Splitter options (choose ONE)	Description
Option SMS	Internal single-mode (9/125 $\mu$ m) and multimode (50/125 $\mu$ m) splitter
Option SXT	No splitter (external splitter supplied by user)
Advanced options	Description
Option JSA	Jitter spectrum analysis and clock recovery emulation
Optional accessories	Description
N1077A-CR1	Clock recovery phase matching kit for N1077A optical (re-order N1027A-77A) Kit includes optical delay matching SM/MM cables, one 6-dB equalizer, one 9-dB equalizer.
N1077A-EQ6	Equalizer, 2.92 mm (m) to 2.92 mm (f), 6 dB (re-order N1027A-EQ6)
N1077A-EQ9	Equalizer, 2.92 mm (m) to 2.92 mm (f), 9 dB (re-order N1027A-EQ9)
N1077A-1CM	Single instrument rack mount kit (re-order N1027A-1CM)
N1077A-1CN	Dual instrument side-by-side rack mount kit (re-order N1027A-1CN)
R1280A	Return to Keysight service center - warranty and service plan
R1282A	Return to Keysight service center - calibration plan

## N1078A optical/electrical clock recovery

Model number	Description
N1078A	Optical/Electrical clock recovery
Baud rate (choose ONE)	Description
Option 216	Supported input rates: 125 MBaud to 16 GBd
Option 225	Supported input rates: 25 GBd to 29 GBd
Option 232	Supported input rates: 125 MBaud to 32 GBd
Option 253	Supported input rates: 53 GBd to 58 GBd
Option 264	Supported input rates: 125 MBaud to 64 GBd
Splitter options (choose ONE)	Description
Option SMS	Internal single-mode (9/125 $\mu$ m)
Option SXT	No splitter (external splitter supplied by user)
Advanced options	Description
Option JSA	Jitter spectrum analysis and clock recovery emulation
Option EVA	Integrated variable equalizers on data + and data - inputs
Optional accessories	Description
N1078A-CR1	Clock recovery phase matching kit for N1076B
N1078A-1CM	Single instrument rack mount kit
N1078A-1CN	Dual instrument side-by-side rack mount kit (re-order N1027A-1CN)
R1280A	Return to Keysight service center - warranty and service plan
R1282A	Return to Keysight service center - calibration plan

N1076/7/8 clock recovery instruments are controlled via a USB connection to an 86100D DCA-X mainframe, or to a standalone PC, running N1010A FlexDCA software. The latest version of FlexDCA may be downloaded from: [www.keysight.com/find/flexdca\\_download](http://www.keysight.com/find/flexdca_download).

## Accessories

For accessories, please see the DCA Accessory Guide, pub number [5991-2340EN](#).

For more information:

[www.keysight.com/find/n1076a](http://www.keysight.com/find/n1076a)

[www.keysight.com/find/n1077a](http://www.keysight.com/find/n1077a)

PCI-SIG®, PCIe® and the PCI Express® are US registered trademarks and/or service marks of PCI-SIG.

Learn more at: [www.keysight.com](http://www.keysight.com)

For more information on Keysight Technologies' products, applications or services, please contact your local Keysight office. The complete list is available at: [www.keysight.com/find/contactus](http://www.keysight.com/find/contactus)

